

## IMPORTANT

You should have already received a copy of the Sliding Folding Pre-Installation Information leaflet. This can be downloaded from [www.jeld-wen.co.uk](http://www.jeld-wen.co.uk) if required.

Part M primary access compliance is only achieved if all doors leaves are opened and is dependant on the installation detail used. If in doubt consult your building designer.

All loads are taken on the head track (to ensure smooth, light operation and long life) thereby avoiding troublesome bottom track loading prone to dirt and restriction.

Prior to installing this doorset, inspect for damage and do not proceed to fit if any noticeable damage or defect is evident. This doorset should be stored in a dry flat location before installation.

## CAUTION

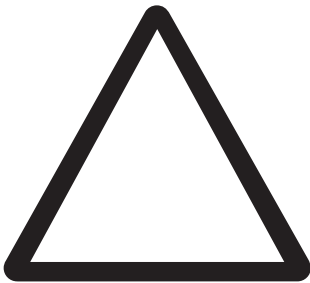

**SAFETY:** This product needs to be installed by a competent tradesperson with assistance.

Two people are required to carry out the installation, as some components are heavy. The outer frame requires fixing to the supporting structure above the opening. The Lintel **MUST** be capable of carrying the load of the doorset in all conditions. If in doubt check with a structural engineer.

Ref WD\_M\_0002\_B

## Fitting and Fixing Instructions

### Sliding Folding Patio Doorset

#### Introduction

To enable the arrangement of doors of the Sliding Folding Patio Doorset to operate either from the left or right certain operations that determine the handing of a door leaf will need to be undertaken on site.

The stiles of the door leaves will need to be pilot drilled to suit the arrangement of the hinges and holes to receive the lock cylinder and the bottom fixing screw of the handle set will need to be added to the mortise in the stile of the locking door leaf.

Information showing the position of the hinges and the preparation to the lock mortise are given in these instructions.

Prior to receipt of the doorset you should have received an advanced information sheet advising you of the need to check that a suitable structure has been prepared to which the head track of the doorset can be fixed and that will be able to support the additional loads imposed by the door leaves.













This leaflet can be down loaded from

[www.jeld-wen.co.uk](http://www.jeld-wen.co.uk)

#### Index:

- 1 – Frame Fixing Pack.
- 2 – Structural opening
- 3 – Preparing the sill for assembly
- 4 – Frame assembly
- 5 – Fixing the frame into the structural opening
- 6 – Preparing the doors to receive the hinges
- 7 - Fitting the multipoint lock
- 8 – Preparing for multipoint lock keeps.
- 9 - Fitting the carrier and pivot hinges
- 10 – Hanging the doors
- 11 – Fitting the keeps and blanking plates
- 12 – Fitting the handles and lock cylinder
- 13 – Adjusting the doors
- 14 – fitting the ventilator
- 15 – Finishing and maintenance
- 16 – Guarantees
- 17 – JELD-WEN product registration form

## 1. Frame Fixing Pack

54	3.5x37 CSK Pozidrive Twinhead Woodscrew	
14	7mm Brown Masonry Plugs	
18	5x80 self drilling screw CSK Pozidrive	
10	8x100 Nylon Frame Anchor	
8	5x90 CSK Pozidrive Woodscrew	
6	3.5x25 PAN Pozidrive Woodscrew	
10	Brown M6 push-in cover	
10	White M6 push-in cover	
14	147x17 Tie Plate	
20	100x24 Wedge Packer (1 to 4mm)	
46	100x24 Flat Packer (3mm)	
64	100x24 Flat Packer (1mm)	

The number of components in the frame fixing pack suit the installation of a 4.2m wide doorset. For other widths there will be excess fittings.

## 2. Structural Opening

To ensure correct operation of the Sliding Folding Patio Doorset it is necessary for the top track to be fixed to a suitable structure that is capable of supporting the loads imposed by the doors, glazing and hardware. The Pre-Installation Information Sheet, that you should have already received, gives information relating to these loads.

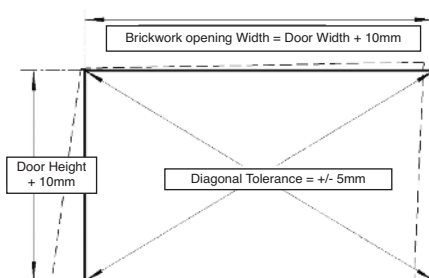

\*Width and height are actual frame sizes

Module Size	Frame Width*	Frame Height*
1800mm	1795mm	2095mm
2100mm	2095mm	2095mm
2400mm	2395mm	2095mm
3000mm	2995mm	2095mm
3600mm	3595mm	2095mm
4200mm	4195mm	2095mm

It is recommended that the opening into which the Sliding Folding Patio Doorset is to be installed is 10mm larger in both height and width than the overall doorset sizes that are given in the table.

The horizontal and vertical surfaces should be checked with a spirit level and the diagonals of the opening should be within 5mm of each other.

### 3. Preparing the Sill for Assembly

Prior to assembling the frame prepare each component for installation by drilling as described below;

#### Sill assembly

If the aluminium section and timber part of the sill are not pre-assembled they should be fixed together as follows; apply a bead of silicon to the rebate in the top of the timber part (as shown) push the timber part into the aluminium part so that it is fully home.

Pilot drill, 2.5 x 25mm through the three fixing holes in the underside of the aluminium part fix, from the underside, using 3No. 3.5 x 25 pan head screws.

#### Pilot Drilling For Tie Plates

In preparation for the sill fixings pilot drill 2.5 x 25mm into the underside of the sill assembly, through the aluminium and into the timber, at the positions shown in the frame fixings diagram, 100mm, 250mm and 400mm from each end then at not more than 400mm centres in between.

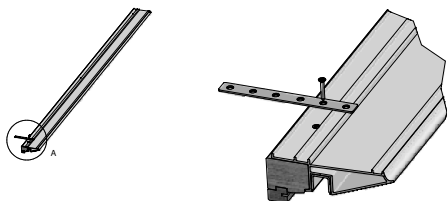

### 4. Frame Assembly

The four assemblies that together form the frame of the Sliding Folding Patio Doorset are fixed together using the 8 No. 5 x 90 woodscrews and the gaskets.

Apply gaskets to:

- each end of the head assembly
- either side of the tenon at the mill end of each jamb assembly
- each end of the stops of each jamb assembly

Screw fix the jamb assembly to the head assembly with 2no 5x90mm woodscrews in each end.

Locate the tenon at the sill end of the jamb assembly into the channel in the sill assembly and screw-fix with 2 No. 5 x 90 woodscrews.

Check that the corners of the frame are square and that the diagonals of the frame measure to within 5mm of each other.

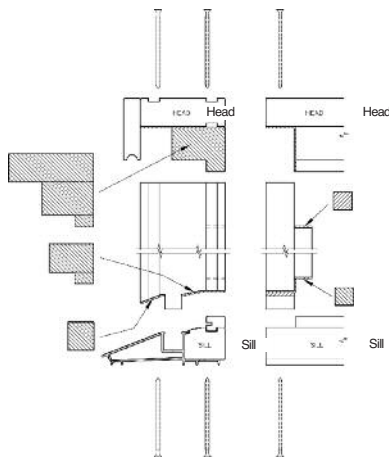

If they do not, loosen the screws at the joints, adjust the frame then retighten the joints.

Secure the Tie plates to the underside of the frame using the 3.5 x 37 woodscrews at the positions prepared with pilot holes.

Ensure the tie plates are fixed through both the aluminium and timber profiles.

## Fitting and Fixing Instructions

### Sliding Folding Doorset

## 5. Fixing Frame in Opening

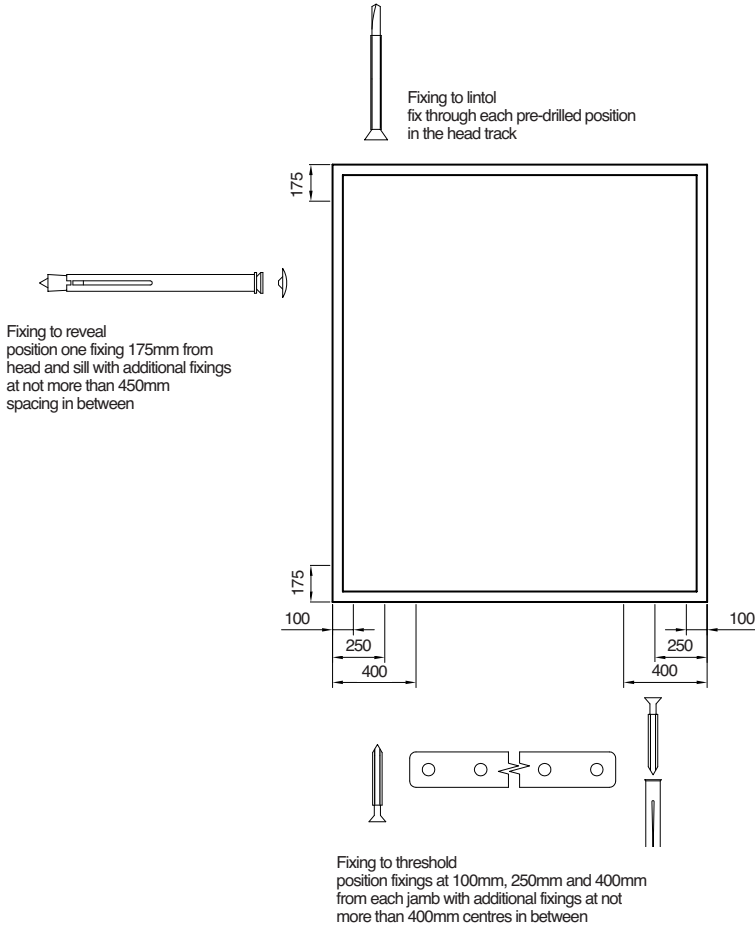

Offer the frame into the structural opening and adjust its position to ensure that the fixing holes in the head track are in the correct position to match the supporting structure (i.e. in the centre of the external flange of a lintel)

### Pre-drilling

Once the position of the frame is correct, pre-drill the lintel with a 4mm diameter hole using the prepared holes in the head track as a guide.

Remove the frame head, from this position, to allow pre-drilling of any masonry above the lintel.

The masonry will need to be drilled through the 4mm holes in the lintel to a depth of at least 40mm to receive the length of the fixing screw that passes through the lintel.

## Locating the Frame

When the position of the frame is correct place 5mm of packing above each jamb between the head and the top of the structural opening then place packers below the sill until the head packers are tight.

Using a spirit level, check that the head and sill are level, make adjustments as necessary, then pack at each of the sill fixing points ensuring that the sill remains level.

Use the spirit-level to check that the jambs are vertical. Position packers at each of the jamb fixing points ensuring that the diagonals of the frame remain within 5mm of each other.

## Fixing Jambs

While the frame is temporarily secured by the packers, and ensuring the frame is not knocked out of position, drill 8mm diameter holes 70mm into the structure either side of the frame through the prepared holes in the jambs.

Insert the frame fixing bolts through the jambs and into the structure and tighten ensuring the jambs are not distorted.

## Fixing the Sill

For each of the sill ties locate a suitable fixing point and drill for the 7mm masonry plug then fix the sill ties using the plugs and the remaining 3.5 x 37 woodscrews.

Check once more, that the jambs are vertical, that the head and sill are level and that the diagonals are within 5mm of each other.

## Fixing the Head

In order to produce a camber in the head track as shown opposite the fixings to the head need to be fitted in stages reducing the gap between the head

and the supporting structure at each stage.

Starting with the two outer fixings offer up the fixing screw and tighten until it is just pulling. DO NOT FULLY TIGHTEN AT THIS STAGE.

At a central fixing point lightly tighten a screw until the head is pulling close to the lintel.

Working from the jambs inwards lightly tighten screws varying the thickness of packing between the head and the lintel creating a slight upwards curve to the head varying from approximately 5mm at each jamb to zero in the middle.

Once the correct curve of the head has been achieved tighten the fixing screws. DO NOT OVERTIGHTEN.

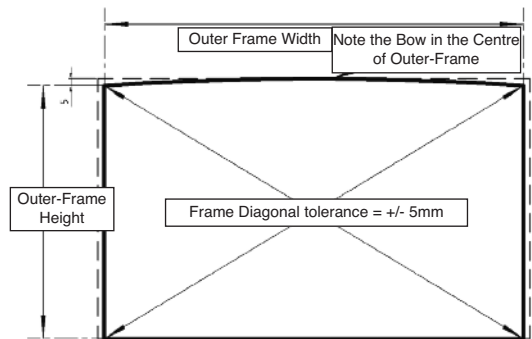

## Fitting and Fixing Instructions

Sliding Folding Patio Doorset

### 6. Preparing the Doors to receive the Hinges

The edges of the door leaves will need to be pilot drilled in preparation for the hinges to be fitted. Using the hinges as a template, position the hinge as shown in the relevant diagram and drill a hole of 3.0mm diameter and 30mm deep. Ensure that the knuckle of the hinge is pressed firmly against the correct face of the door.

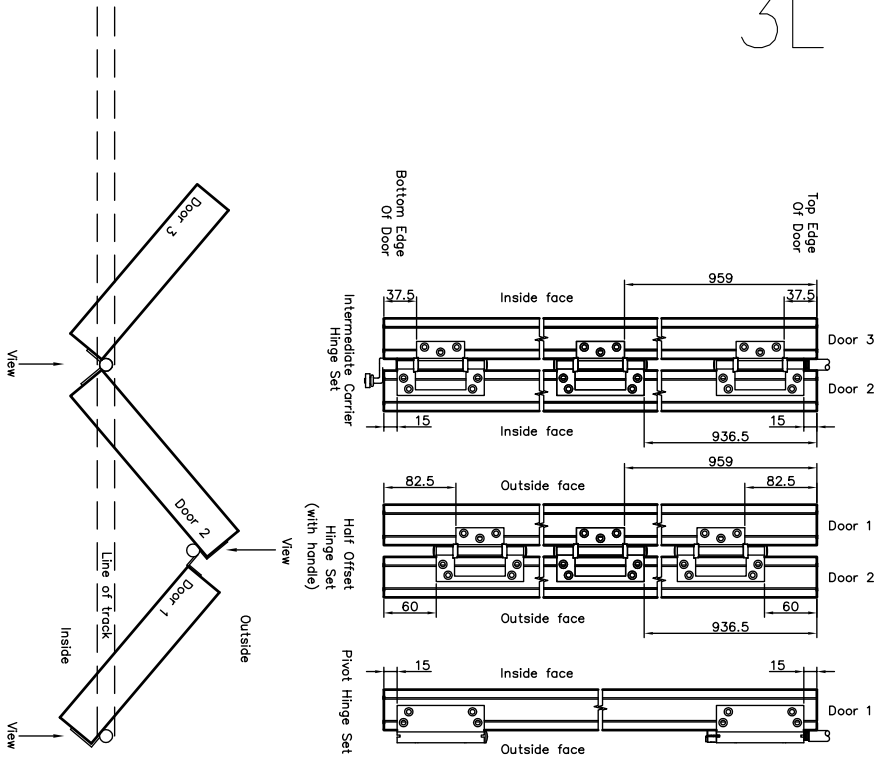

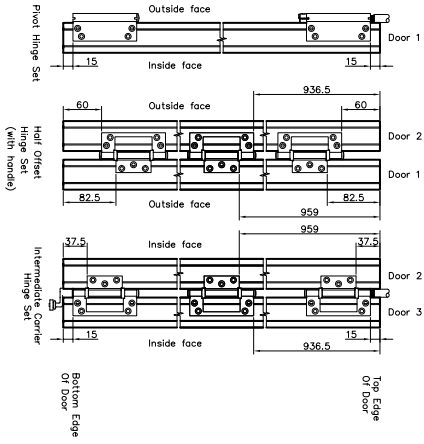
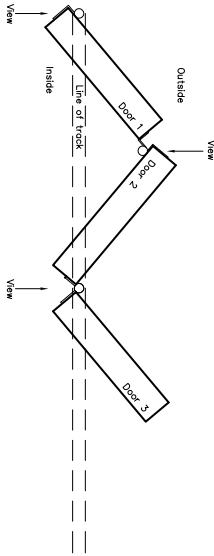

3R

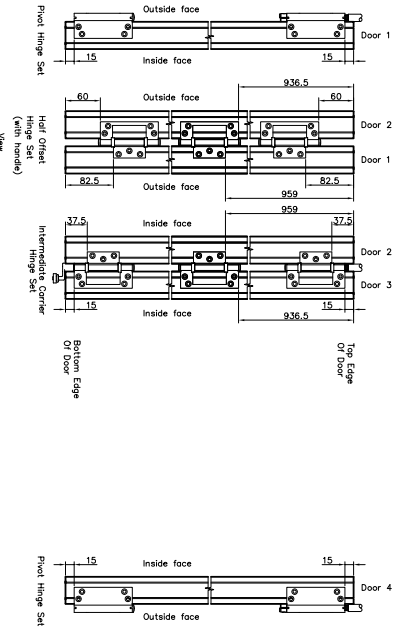
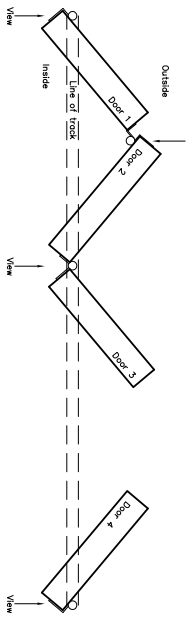

1L3R

# Fitting and Fixing Instructions

## Sliding Folding Patio Doorset

# 3L1R

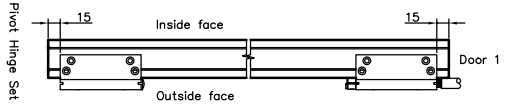
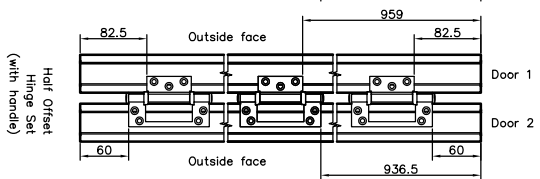
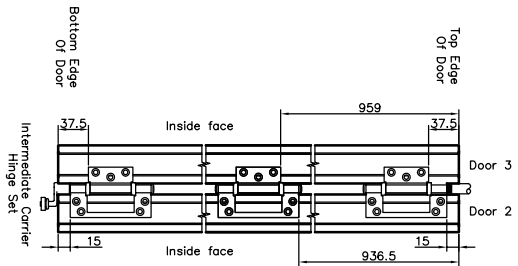
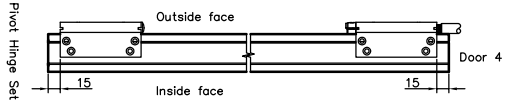
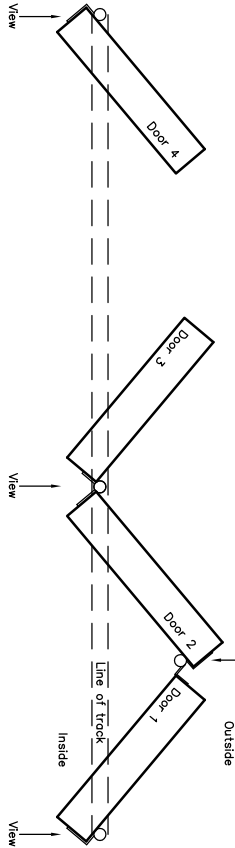

5R

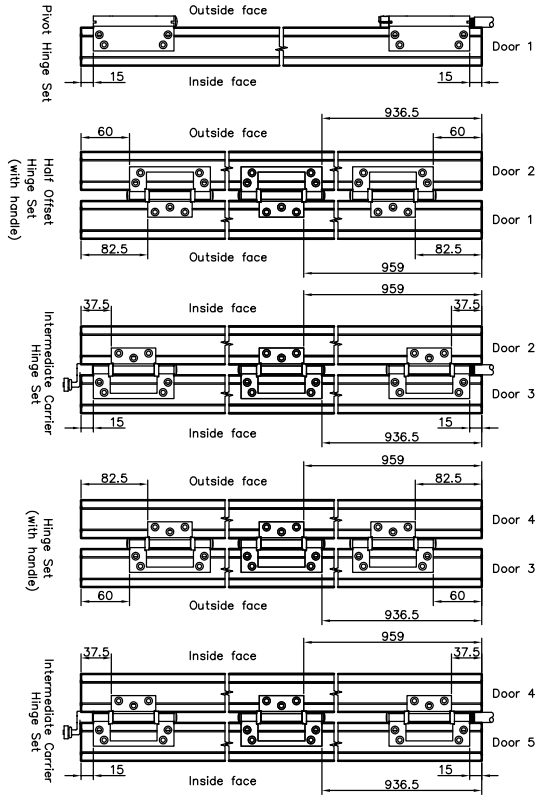
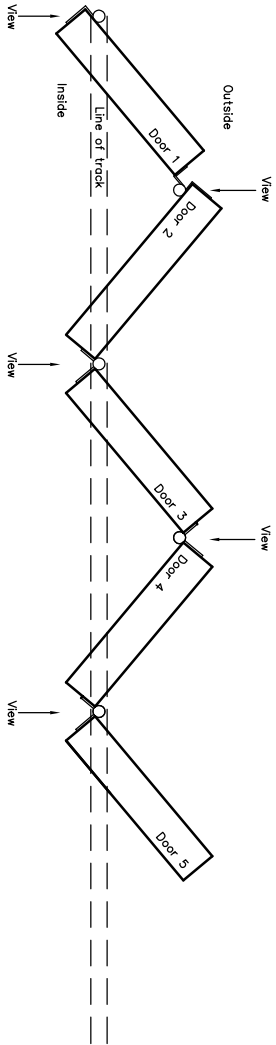

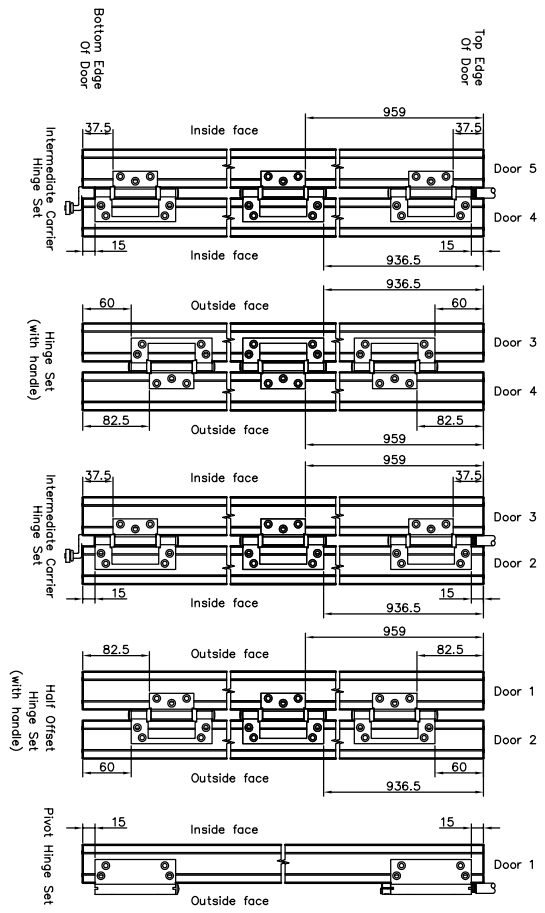
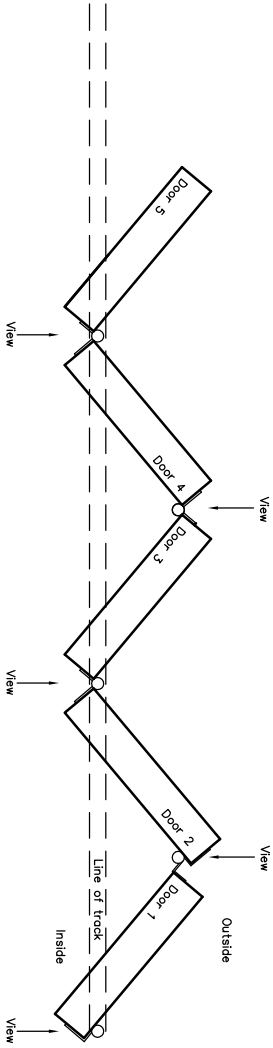

# 5L1R

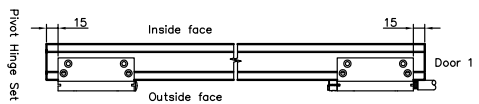
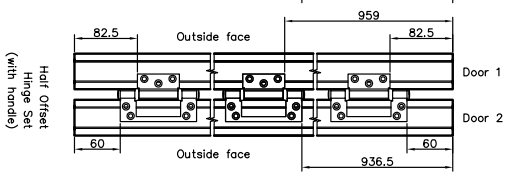
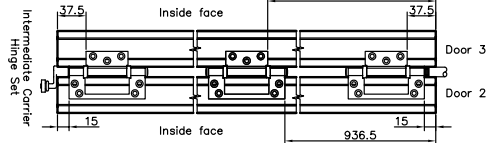
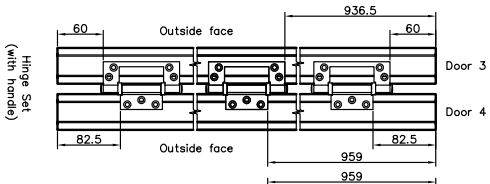
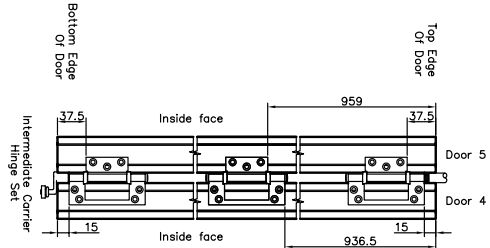
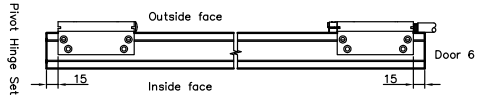
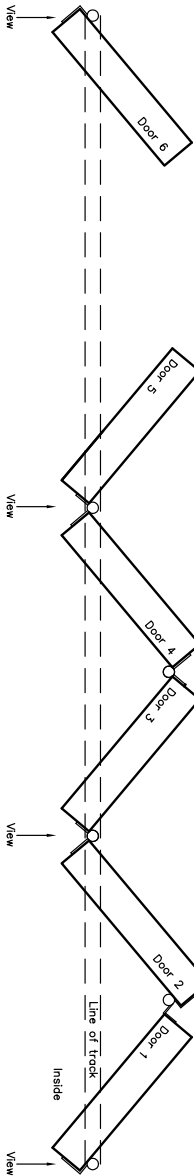

# 1L5R

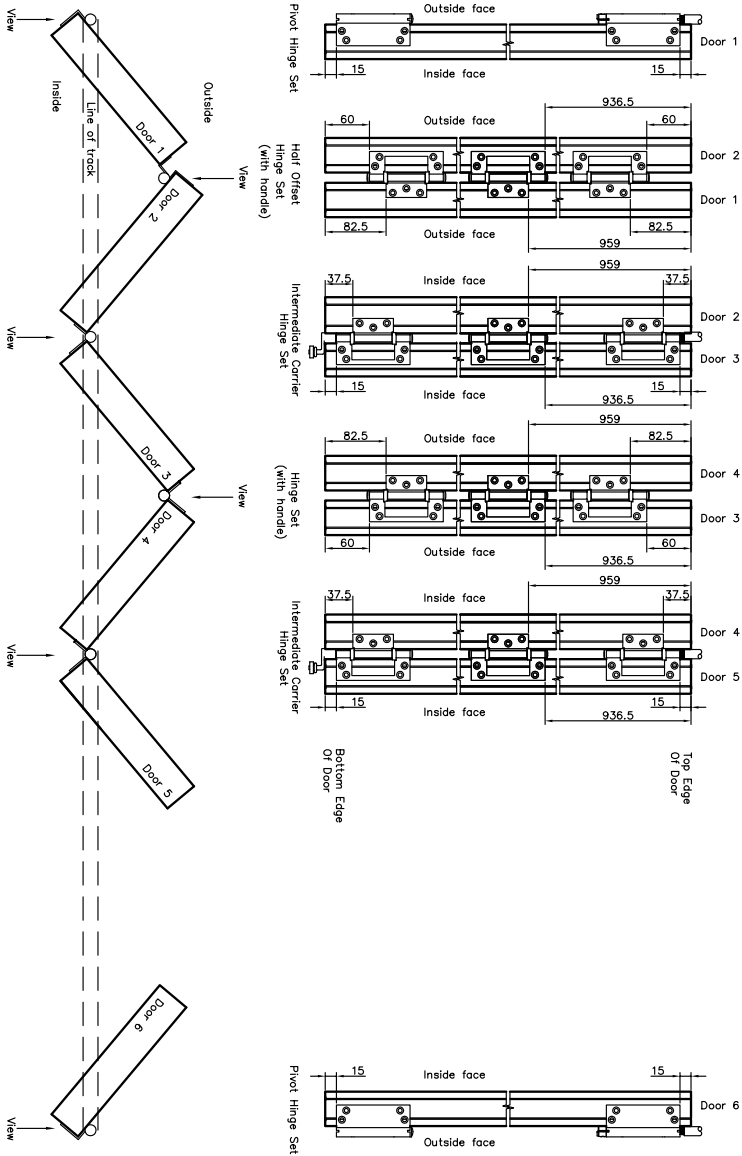

# 3L3R

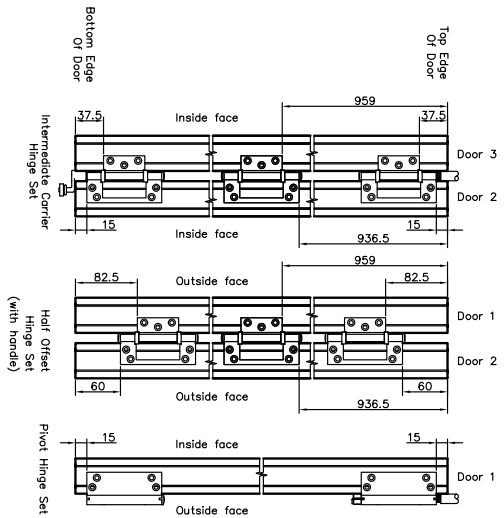
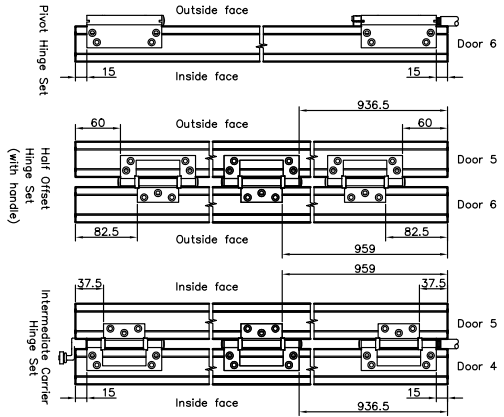
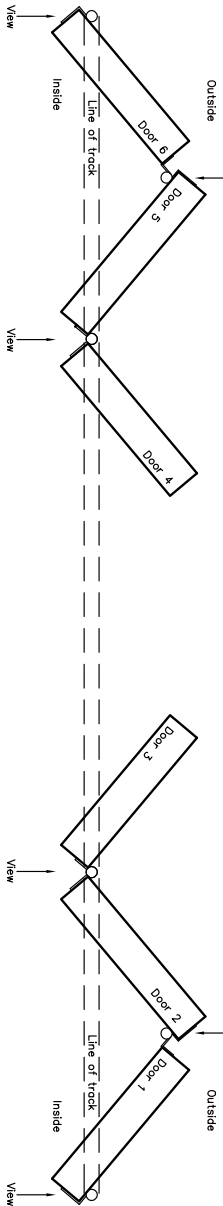

## 7. Fitting the multipoint lock

The door leaf that is to receive the multipoint lock is mortised and machined for the face plate of the lock. Once the handing of the door is determined and therefore the top and bottom edges of the doors are established, additional holes need to be prepared through the central mortise as shown on the diagram below.

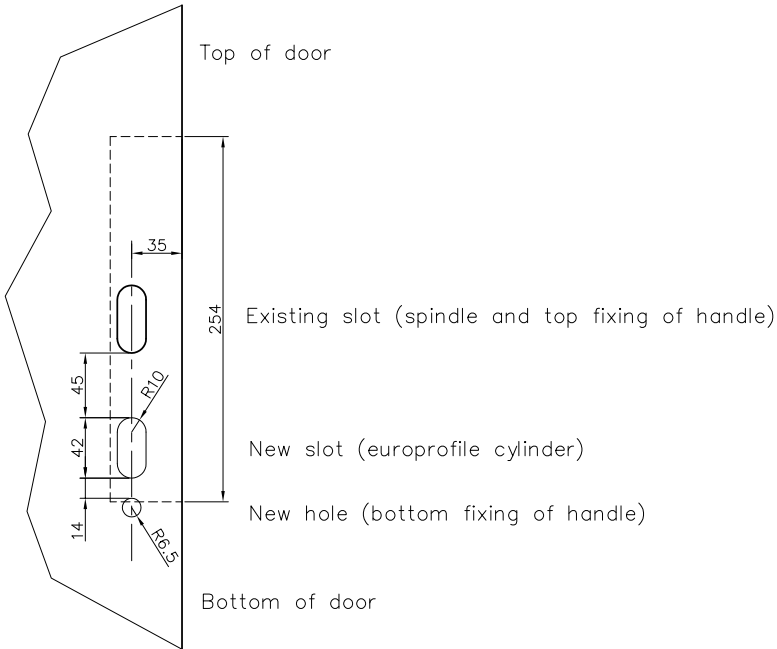

The multipoint lock is fitted into the machined edge of the door, positioned to match the newly prepared holes in the central mortise. It may be useful to loosely fit the handles, spindle and euro-cylinder to locate the lock accurately (see section 12). Pilot drill each fixing position in the face-plate of the lock with holes of 3.0mm diameter and 30mm deep. Secure the lock with the 3.5 x 37mm woodscrews.

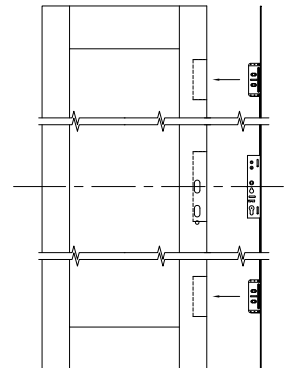

## 8. Preparing for multipoint lock keeps

For door arrangements other than 3L, 3R, 5L and 5R one door has been machined to receive the keeps for the multipoint lock and will need to be prepared to fit the striker of the central keep as shown in the diagram below.

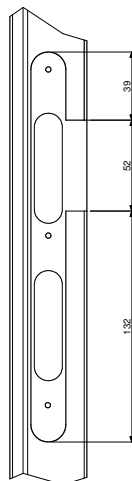

## 9. Fitting the carrier and pivot hinges

In preparation for hanging the door leaves the carrier hinges need to be fitted into the top track in an appropriate order to suit the desired arrangement of doors. All the carrier hinges are fed into the track through the cut-outs that can be at one or both ends of the top track. The top and bottom blocks of the pivot hinges need to be positioned so that the adjustment screws can be accessed after the doors are fitted as shown in the diagrams.

Note: It is not important which end of the track the cut-out is located but the carrier hinges must be fed into the track in the correct order.

Door Arrangement	Position of carrier hinges viewed from the outside			
	Left Hand Side			Right Hand Side
3L	Pivot	Intermediate Carrier		
3R			Intermediate Carrier	Pivot
3L 1R	Pivot	Intermediate Carrier		Pivot
1L 3R	Pivot		Intermediate Carrier	Pivot
5L	Pivot	Intermediate Carrier	Intermediate Carrier	
5R		Intermediate Carrier	Intermediate Carrier	Pivot
5L 1R	Pivot	Intermediate Carrier	Intermediate Carrier	Pivot
1L 5R	Pivot	Intermediate Carrier	Intermediate Carrier	Pivot
3L 3R	Pivot	Intermediate Carrier	Intermediate Carrier	Pivot

# Fitting and Fixing Guidelines for

## Sliding Folding Patio Doorset

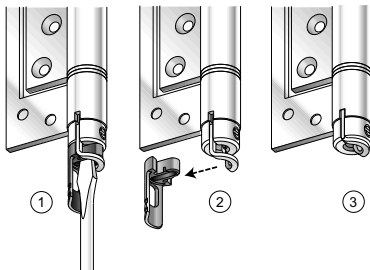
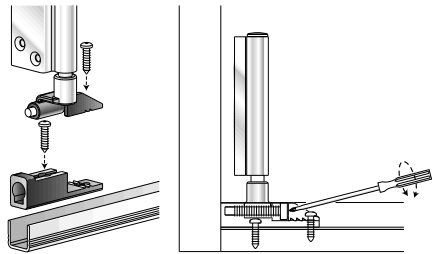
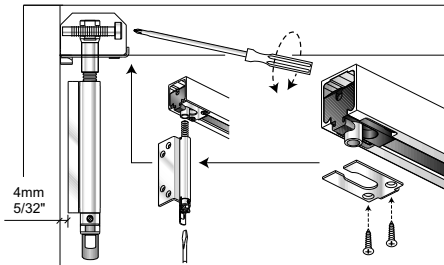
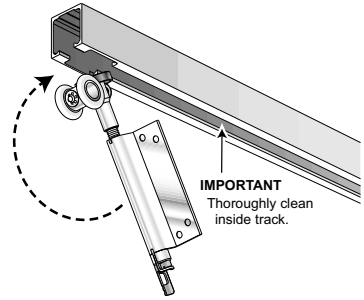
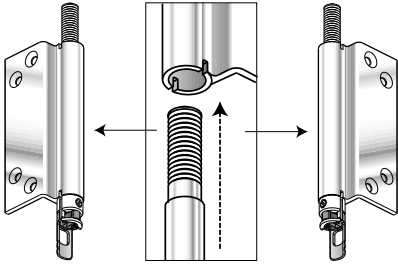

## 10. Hanging the doors

When the glazing is beaded the beads should be facing towards the inside of the building.

Where a hinge obstructs the weatherseal cut the weatherseal around the hinge. The Hinges must not have weatherseal trapped beneath them.

Doors should be fitted to the pivot hinges first. Use the pre-drilled pilot holes to fix the hinge (screws are provided in the hinge pack).

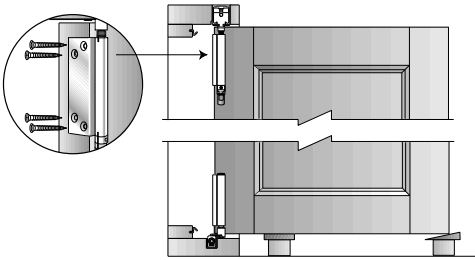

Adjust the top and bottom pivot hinges to ensure the door is vertical before attempting to hang the next door.

Now start adding further panels to the assembly. You must follow the illustrations on the 'Door & Hardware Arrangement Sheet' for correct hardware to be used at the correct position on the doorset. Failing to do so will result in incorrect door assembly and may damage the door panels.

## 11. Fitting Keeps and Blanking plates

To complete the frame installation fit the dropbolt cups, keeps and blanking plates as the positions shown on the arrangement sheet for your doorset.

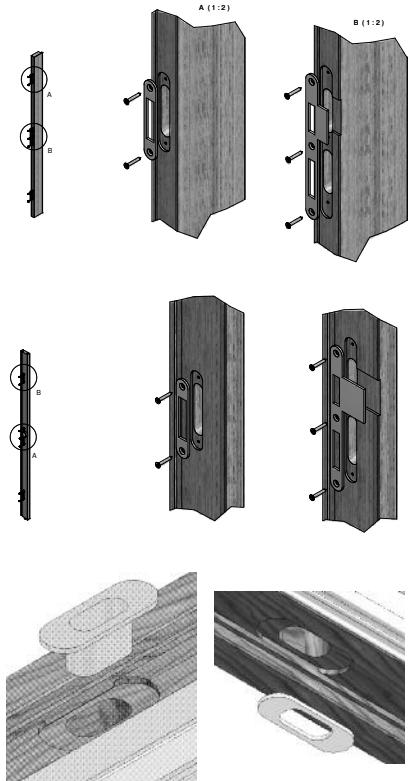

## Fitting and Fixing Instructions

Sliding Folding Patio Doorset

### 12. Fitting the handles and lock cylinder

For the correct operation of the lock, the latch may need to be reversed of the lock.

- Release the screw holding the latch
- Remove the latch, reverse and replace
- Refit the holding screw

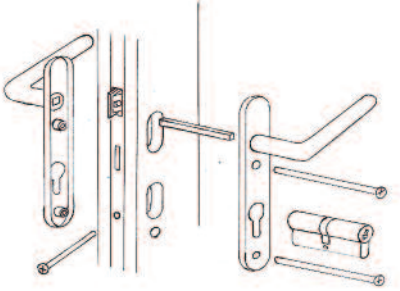

### 14. Fitting the ventilator

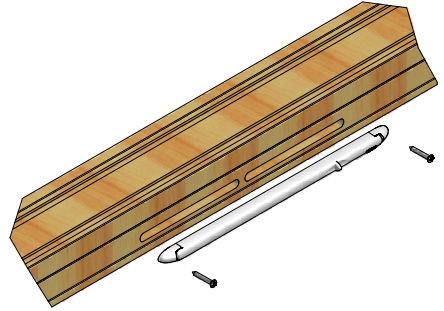

### 13. Adjusting the doors

Adjustments can be made to the top and bottom pivot hinges and to the top intermediate carrier hinge located in the head track.

The top and bottom pivot hinges can be adjusted to move all three doors sideways between the jambs. It is important to adjust both hinges evenly as uneven movement could effect the load supported by the head track.

The top pivot hinge and the top intermediate hinge can be used to raise and lower the doors. Again, these should be adjusted together to ensure an even distribution of load.

The doors should be adjusted so that there is an even gap at the head, sill and jambs.

The target clearance at the head and sill is 5mm and that at the jambs is 8mm.

If movement of the timber has occurred creating clearances greater than the target dimensions the gap at the multipoint lock should be altered by adjusting the pivot hinge(s) so that the latch engages correctly. This may create a clearance at the pivot hinge greater than 8mm but this will be accommodated by the weatherseals on the stile and jambs.

# 15. Finishing & Maintenance

## Finishing

After finishing the installation of your doorset, check that all the fixings are secure and all the specified dimensions are achieved. It is vital for proper operation and long life of your Patio doorset.

The folding sliding doorset is supplied in;

- 1) Unfinished
- 2) Basecoat stained or primed
- 3) Factory finished

Factory finished requires no further decoration other than touching up damage that may have occurred during installation,

The hardwood unfinished doorset must be primed or sealed immediately after delivery/ collection and prior to installation. This should be carried out in dry weather conditions. All faces, edges and any cutouts should be suitably sealed immediately after un-wrapping. Before priming or sealing lightly sand off any handling marks and variations caused by exposure and ensure the surface is dust free.

Unfinished hardwood can be resinous and will need to be suitably sealed prior to finishing. For paint finishes aluminium primers can provide suitable blocking properties.

Microporous paints and woodstains are recommended for all exterior products.

The manufacturers instructions should be followed. 'Low Build' stains and Danish Oil should not be used.

Pigmented translucent finishes generally perform much better than clear. It is recommended that dark coloured stains or paint should be avoided if the doorset is exposed to the full heat of the sun, particularly on south or south west elevations. Dark finishes increase surface temperatures and cause excessive drying out, this can lead to surface deterioration requiring more regular maintenance.

## Maintenance

These products must be installed in accordance with accepted good trade practice (and in accordance with supplied instructions where applicable), and maintained in accordance with these procedures or else the warranty shall be void.

## Automatic Closers And Operators

All Door Hardware systems supplied are designed for manual operation only.

## Hardware

In buildings is subject to deterioration from everyday use, and also from environmental attack due to atmospheric and other conditions. Maintenance of hardware is even more important in severe environments such as coastal marine areas, and some industrial areas. Even stainless steel products require maintenance to prevent deterioration in some environments.

JELD-WEN UK Ltd requires the following minimum maintenance to be followed otherwise the warranty shall be void.

## Track And Bearings

Using a spatula or similar item (not your finger), apply a small amount (typically a 1/4 teaspoon) of white petroleum jelly (Vaseline) or similar lubricant to the inner lip of each side of the track. Ensure that the wheels pass through the lubricant and it is distributed evenly along the track. Put additional lubricant around bearings. Lubricant reduces wear, improves smoothness and further protects against corrosion of track and bearings. Remove all surface contaminants by wiping all visible track surfaces with a damp soft cloth and a mild detergent, then wipe clean with a clean cloth. In severe environments, apply a thin film of a corrosion preventative by wiping with a soft cloth moistened with one of corrosion preventative products.

Stainless-steel bearings are manufactured from hardening-grade stainless steel and although this material performs considerably better than plated steels, it is still susceptible to corrosion unless maintained as described above.

## Hangers, Pivots And Brackets

A light spray application of a corrosion preventative followed by a light wipe with a dry cloth to remove excess is recommended to all hangers, pivots and brackets. Exposed surfaces should first be wiped down with warm soapy water and a soft rag, and then rinsed clean before applying preventative.

## Fitting and Fixing Instructions

### Sliding Folding Patio Doorset

#### Hinges

Wipe down the visible surfaces with warm soapy water on a soft rag and then rinse off by wiping with a clean damp rag. Application of a thin film of a light machine oil or one of the corrosion preventative sprays will help to maintain the original lustre of the metal finish. Be careful not to get these compounds on the timberwork itself as they may cause staining.

#### Dropbolts

Spray application of a suitable lubricant to the sliding pin inside the bolt and to the lock cylinder is recommended. A tube attached to the nozzle will help to concentrate the spray where you want it to go. There are access holes or slots on all dropbolt products so that this can be done without removing the locks from the doors.

#### Handles

Refer to leaflet in box.

#### Frequency

The procedures mentioned above need to be carried out as often as is necessary to prevent deterioration in the installed environment, however we recommend the following minimum frequency of application:

- General environments 6 monthly
- Marine and industrial environments 3 monthly

Regular maintenance is required to all hardware, even stainless steel; otherwise the manufacturer's warranty may be voided.

## 16. Guarantees

In keeping with our quality policy, JELD-WEN offers the following guarantees on its products. These guarantees are subject to JELD-WEN UK Terms and Conditions of Sale. Defects that are caused in whole or in part by failure to adhere to JELD-WEN UK recommendations relating to storage, handling, installation, decoration, glazing and maintenance, are not covered by the guarantees overleaf:

- 10 10-year guarantee against manufacturing defects**
- 10 10-year guarantee on insulating glass units**  
Only insulating glass units supplied by JELD-WEN UK are covered by this Guarantee, these are stamped and identified accordingly.
- 30 30-year guarantee against fungal attack**  
Against rot and fungal attack on all external timber components.
- 10 10 year guarantee on Hi-build factory painted external joinery in accordance with EN927/1-7**
- 6 6 year guarantee on Hi-build factory stained external joinery in accordance with EN927/1-7**
- 6 2 year guarantee on Hi-build Oak lacquer finish**

Exceptional wear and tear of hardware through extreme use is not covered. JELD-WEN will accept no responsibility for products cut down in size after receipt, or when utility or structural strength is impaired in fitting or application of hardware.

Hinges, aluminium rails and other hardware fitted must never be painted, and must be kept clean and lightly lubricated at all times. Use Vaseline or neutral oil. Keep rivets and moving parts lightly lubricated. Lubricate at least once a year, in coastal areas and/or places with high pollution, clean and lubricate more often.

The fitting instructions where supplied must be followed and the assembly, fitting procedures described must be strictly adhered to. Copies of product fitting instructions are available for download from [www.jeld-wen.co.uk](http://www.jeld-wen.co.uk)

All joinery shall be installed correctly in accordance with normal trade practices and adequately maintained in service.

All undecorated joinery supplied in the white must be suitably primed or stained without delay after receipt and all joinery supplied primed must receive further coats (undercoat and top coat) of paint within three months of purchase. If primed, and in particular basecoat stain finishes have deteriorated because of prolonged exposure, the surface must be properly prepared and re-primed before finishing. Knotting solution should be applied over any visible knots on primed or part finished painted products. Those products supplied with a basecoat stain need either a second basecoat, or an application of medium to high build stain within 1 month of exposure.

These are the minimum requirements and further finishing coats must be applied to the manufacturers' recommendations to afford full protection.

Take care not to paint over any form of weather stripping, as this will adversely affect their performance.

Any surfaces subsequently cut, particularly those exposing end grains, must be brush coated with preservative and if required for paint finish must also be primed before the joinery is fixed in position in accordance with British Standards or Euro codes.

Standard insulating glass units must not be used in areas of high humidity, e.g. swimming pools or similar. They should also not be used within 300mm from a door or within 800mm of the floor.

Contact JELD-WEN if in doubt for your particular installation or refer to Page 08 of JELD-WEN's Timber Window Technical Specification Guide available upon request (Tel 0845 122 2890) or as a download from [www.jeld-wen.co.uk](http://www.jeld-wen.co.uk)

The decorative finish applied to external joinery must be maintained in service and moisture must not be allowed to penetrate into the timber throughout its life.

Regular maintenance of the paint or stain finish of the frame is essential for the long-term performance of all the components of your patio doorset. The period between maintenance checks will vary depending on the type of paint or stain finish and also the local conditions for the site. External joinery products must be cleaned at a maximum of six monthly intervals using a mild non-abrasive cleaner and soft cloth. Both internal and exterior faces should be cleaned.

Make regular checks to ensure that any drainage holes, channels and spaces are kept clear. Use a soft flexible brush or pipe cleaner with care to remove obstructions.

Finished joinery is guaranteed against blistering, cracking, flaking or erosion excluding natural resin exudation and movement around knots.

Annual inspection should be made and touching up carried out as necessary in areas of wear and tear (for example, exposed areas of sills or where the paint film has been breached).

Guarantees to the finished product are also on condition that:

- No physical or chemical damage to the doorset or coating has occurred
- No repairs or alterations to the surrounding buildings have occurred which are detrimental to the joinery performance.
- No failure of the coating has occurred caused by failure of ancillary products, or glazing.
- No damage to the coatings has occurred prior to, or during, installation.
- No damage to the coating has occurred, caused by bad maintenance of the building or poor design of the building.

Further installation and handling information is available by downloading a copy of JELD-WEN's Timber Windows Technical Specification Guide at [www.jeld-wen.co.uk](http://www.jeld-wen.co.uk)



## 17. JELD-WEN Product Registration Form

To register under our priority guarantee scheme, please complete and return the form below. Registered installations will be given priority by our customer care team and no call-out charge will be made in the event of service calls. Any manufacturing defects will be repaired free of charge. Installation defects will be charged for parts and labour only.

1. Builder / Installer's name and address (if applicable)

---

2. Owner / occupier's name

---

3. Installation address

---

---

---

4. Product installed: \_\_\_\_\_

5. Date of installation: \_\_\_\_\_

6. Did you understand the fitting instructions? Yes / No

7. Was the product decorated before installation / assembly? Yes / No

8. Were parts clearly identifiable and correct? Yes / No

If "no" please give details:

---

---

9. Have you any comments to add?

---

---

---

---

---

Thank you for your assistance. We trust you are pleased with your Patio Door Set. This information is required for guarantee registration and product improvement only. It will not be passed to any third party. Your statutory rights are not affected.

## **Fitting and Fixing Instructions**

Sliding Folding Patio Doorset

JELD-WEN UK LTD  
Snow Hill  
Melton Mowbray  
Leicester LE13 1PD

T: 01664 484500  
F: 01664 484502

SS/MFD/UMG614/3K/MAY09